

1. A girl throws a ball at a vertical wall 4 m away (as shown in the diagram). The ball is 2 m above the ground when it leaves the girl's hand with an initial velocity of  $v_0$  14.14 m/s and an angle  $45^\circ$  above the horizontal ( $v_x = 10$  m/s and  $v_y = 10$  m/s). When the ball hits the wall, the horizontal component of its velocity is reversed, while the vertical component remains unchanged. How far from the wall does the ball hit the ground?

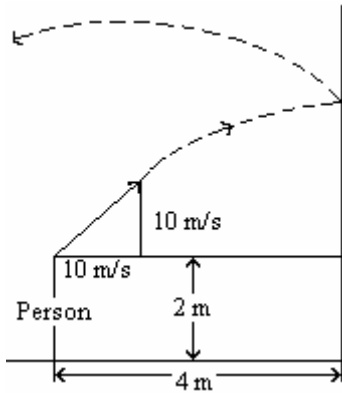

- a. 19.3 m
- b. 18.2 m
- c. 17.0 m
- d. 15.9 m

2. A stone of mass  $m$  is attached to a light strong string and whirled in a vertical circle of radius  $r$ . At the exact bottom of the path the tension in the string is three times the stone's weight. The stone's speed is given by:

- a.  $2\sqrt{gr}$
- b.  $\sqrt{2gr}$
- c.  $2gr$
- d.  $4gr$

3. A small magnet of mass 1 g is levitated by a piece of superconductor. What is the force the magnet exerts on the superconductor? ( $g = 10 \text{ m/s}^2$ )

- a. 0 N
- b. 0.001 N
- c. 0.01 N
- d. 1 N

4. Two large crates  $m_1$  and  $m_2$  are connected to each other by a stiff massless spring. The force constant of the spring "k" is 8000 N/m,  $m_1$  is 650 kg, and  $m_2$  is 490 kg. A constant horizontal force "F" is applied to  $m_1$  which ultimately gives the two masses and the spring a common acceleration on the frictionless floor. If the spring is compressed 5 cm from its initial unstretched length during the motion, what is the magnitude of the applied force F?



- a. 931 N
- b. 815 N
- c. 759 N
- d. 591 N

5. In an experiment with a block of wood on an inclined plane, with dimensions shown in the figure below, the following observations are made:

- 1) If the block is placed on the inclined plane, it remains there at rest.
- 2) If the block is given a small push, it will accelerate toward the bottom of the incline without any further pushing.

Which is the best conclusion that can be drawn from these observations?

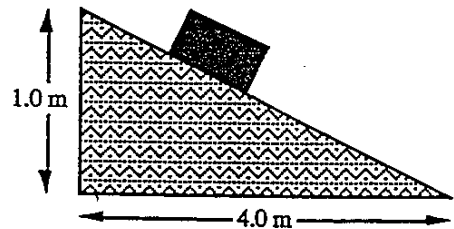

- a. Both coefficients of friction must be less than 0.25.
- b. Both coefficients of friction must be greater than 0.25.
- c. The coefficient of static friction must be less than the coefficient of kinetic friction.
- d. The coefficient of static friction is greater than 0.25 while the coefficient of kinetic friction is less than 0.25.

6. A woman stands on a bathroom scale in an elevator which is not moving. The scale reads 500 N. The elevator then moves downward at a constant velocity of 5 m/s. What does the scale read while the elevator descends with constant velocity?
- 100 N
  - 250 N
  - 450 N
  - 500 N
7. A car enters a horizontal, curved roadbed of radius 50 m. The coefficient of static friction between the tires and the roadbed is 0.20. What is the maximum speed with which the car can safely negotiate the curve?
- 4.5 m/s
  - 10 m/s
  - 20 m/s
  - 40 m/s
8. A group of students need to cross a river in the shortest time. The water in the river flows downstream at a speed of 10m/s. The boat has a maximum speed of 20m/s. In what direction should be the students head the boat?
- Downstream
  - Directly toward the opposite shore
  - $63^\circ$  away from downstream
  - upstream
9. Ying and Albert are carrying Faisal on a horizontal stretcher. The stretcher is uniform, is 2.0 m long, and weighs 100N. Faisal weighs 800N. Faisal's centre of gravity is 75 cm from Ying. Ying and Albert are at the ends of the stretcher. The force that Albert is exerting to support the stretcher with Faisal on it is:
- 250 N
  - 300 N
  - 350 N
  - 450 N
10. John and Jane are 10 m apart on an icy, frictionless lake. Jane's mass is 40 kg excluding the 1 kg ball she holds. John's mass is 59 kg. Jane throws the ball to John with a horizontal velocity of 10 m/s. How far apart are Jane and John 10 s later?
- 12 m
  - 13 m
  - 14 m
  - 15 m
11. A car of mass 1500 kg is travelling around a banked curve which is inclined at an angle of  $15.0^\circ$  above the horizontal.
- 
- The car's path is circular with a radius of curvature of 100 m. Assuming that the road surface is frictionless, What is the speed of the car such that it remains on the banked curve?
- 16.2 m/s
  - 18.2 m/s
  - 20.5 m/s
  - 14.5 m/s
12. A simple pendulum consisting of a mass  $m$  and string, swings upward, making an angle  $\theta$  with the vertical. The work by the tension force is
- zero
  - $mg$
  - $mg\cos\theta$
  - $mg\sin\theta$
13. A 50 kg child sits on a swing, which hangs on ropes 5 m long. The child and swing are released from rest at an angle of  $60^\circ$  to the vertical. What is the combined tension in the two ropes when the child is at the lowest point? ( $g = 9.8 \text{ m/s}^2$ )
- 100 N
  - 245 N
  - 490 N
  - 980 N

14. A hockey puck stuck by a hockey stick is given an initial speed of 10 m/s. If the coefficient of friction between the ice and the puck is 0.1, how far will the puck slide?
- 39 m
  - 45 m
  - 51 m
  - 57 m
15. A Colour Doppler flow meter is used to measure the speed of blood flow in an artery. The speed of sound in blood is  $1570.0 \text{ m s}^{-1}$ . The transmitted frequency is  $f_1$  and the frequency received at the detector is  $f_2$ , where  $f_1 = 1.0005 f_2$ . What is the measured average blood flow speed?
- 0.392 m/s away
  - 0.392 m/s toward
  - 0.432 m/s away
  - 0.432 m/s toward
16. In an ink-jet printer, an ink droplet of mass  $m$  is given a negative charge  $q$  by a computer-controlled charging unit. It then enters at speed  $v$  (see figure below) the region half-way between two deflecting parallel plates of length  $L$  separated by distance  $d$ . Throughout this region a uniform downward electric field exists. Neglecting the gravitational force on the droplet, what is the maximum charge that can be given to that droplet so that it does not hit a plate?

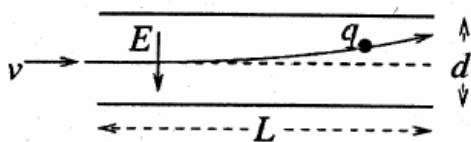

- $\frac{mv^2 E}{dL^2}$
- $\frac{mv^2 d}{EL^2}$
- $\frac{md}{E(vL)^2}$
- $\frac{mv^2}{dL}$

17. A particle (mass  $6.7 \cdot 10^{-27} \text{ kg}$ , charge  $3.2 \cdot 10^{-19} \text{ C}$ ) moves along the positive  $x$  axis at a constant speed of  $4.8 \cdot 10^5 \text{ m/s}$ . It enters a region of uniform electric field parallel to its motion and comes to rest after moving 2.0 m into the field. What is the magnitude of the electric field in kV/m?
- 2.0
  - 1.5
  - 1.2
  - 3.5
18. A 0.1 kg steel ball is dropped straight down onto a hard horizontal floor and bounces straight up. Its speed just before and just after impact with the floor is 10 m/s. Determine the magnitude of the impulse delivered to the floor by the steel ball.
- zero
  - 1 N-s
  - 2 N-s
  - 10 N-s
19. Four identical bulbs are connected in parallel to a 12V ideal battery. Two of them burn out. The remaining two:
- Look brighter than before
  - Look the same as before
  - Look dimmer than before
  - Are off
20. Three resistors,  $R_1 = 9\Omega$ ,  $R_2 = 3\Omega$ ,  $R_3 = 1\Omega$ , are connected in parallel to a 9 V battery. What is the total power dissipated in the circuit?
- 180 W
  - 117 W
  - 99 W
  - 81 W

21. A light ray goes through two thick rectangular slabs of glass, each of the same uniform thickness. The first slab has index of refraction  $n_1$  and the second  $n_2$ . If  $n_1 < n_2$ , how does the original angle  $\theta_i$  compare to the final angle  $\theta_f$  where the ray leaves the second slab going back into air?

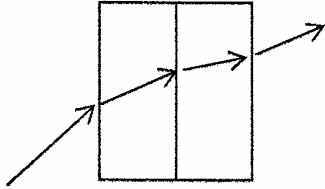

- a.  $\theta_i > \theta_f$
  - b.  $\theta_i < \theta_f$
  - c.  $\theta_i = \theta_f$
  - d.  $\theta_i = (n_1/n_2) \theta_f$
22. A 30 m tall building is being photographed with a camera with a lens of focal length 50 mm. How tall is the image on the film if the building is 100 m away?
- a. 30 mm
  - b. 15 mm
  - c. 10 mm
  - d. 3.0 mm
23. The figure is a scaled diagram of an object and a converging lens. The focal length of the lens is 5.0 units. An object is placed 3.0 units from the lens as shown.

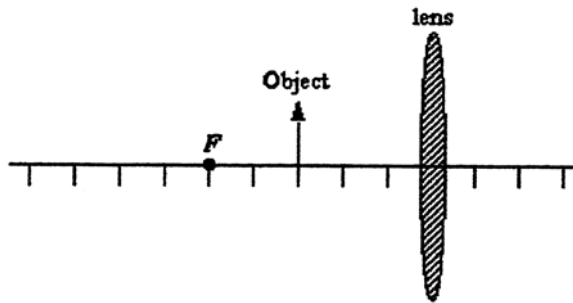

Approximately, what is the image distance?

- a. -2.0 units
- b. -4.0 units
- c. +6.0 units
- d. -8.5 units

24. A cannon fires a projectile as shown. The dashed line shows the trajectory in the absence of gravity. Points M, N, O, and P correspond to one second time intervals. Calculate the heights,  $x$ ,  $y$ , and  $z$ . (All answers are in metres).

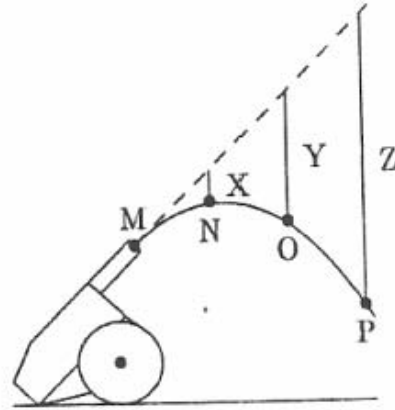

- a. 4.9, 9.8, 14.7
  - b. 4.9, 19.6, 44.1
  - c. 9.8, 39.2, 88.2
  - d. 9.8, 19.6, 29.4
25. There is a kinetic coefficient of friction  $\mu_k = 0.18$  between a box (5 kg) and the surface it is on. The box starts from rest and is pushed with a constant force of 12 N for 5 seconds. What is the total distance travelled by the box before it comes to rest? (All answers are in metres).

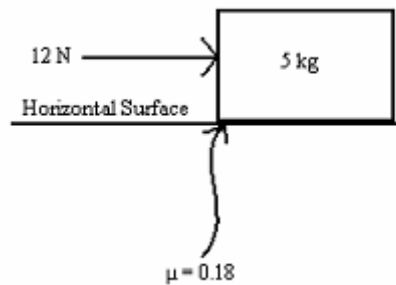

- a. 32.9
- b. 2.9
- c. 13.7
- d. 10.8

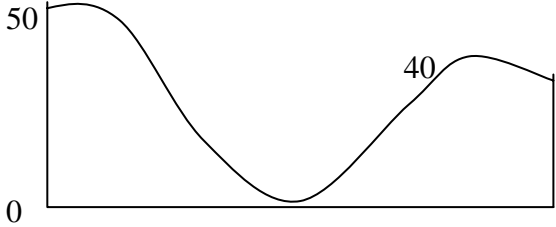
26. A point source of sound on top of a police car emits a signal at 1000 Hz. If the car is traveling in a straight line at 20.0 m/s, what is the perceived wavelength (to three significant figures) as measured by someone standing on the road directly in front of the car? Take the speed of sound to be 335 m/s.
- 0.305 m
  - 0.203 m
  - 0.315 m
  - 0.335 m
27. Converging lenses can produce:
- Only upright images
  - Only inverted images
  - Both upright and inverted images depending on the distance of the object
  - Both upright and inverted images simultaneously
28. An electron is accelerated from rest through a potential difference of  $3.0 \cdot 10^3 \text{ V}$  in a particle accelerator. How fast will it be moving after this acceleration in m/s?
- $8.7 \times 10^8$
  - $2.4 \times 10^3$
  - $2.3 \times 10^6$
  - $3.2 \times 10^7$
29. 10 kg of the isotope tritium, which has a half-life of 12.3 years, is produced at a reactor. Which of the following values, in kg, is closest to the mass of tritium that will remain after 30 years?
- 7.5
  - 1.8
  - 0.9
  - 6.6
30. A roller coaster of mass 200 kg starts from a height of 50.0 m going plunges to a height of 0.0 m, goes then uphill again and comes to rest on top of the hill at 40.0 m height. The total distance travelled is 150 m, and some amount of work was done against frictional forces on the track.
- 
- 750 J
  - 1950 J
  - 1500 J
  - 19600 J
31. A layer of ethyl alcohol (index of refraction  $n = 1.361$ ) lies on top of water (index of refraction  $n = 1.333$ ). At what angle relative to the normal to the interface between the two liquids, to the nearest degree, is the light from ethyl alcohol to water totally reflected internally?
- $78^\circ$
  - $88^\circ$
  - $68^\circ$
  - There is no critical angle
32. A compound microscope is made with an objective lens with focal length  $f_o = 0.90 \text{ cm}$  and an eyepiece with focal length  $f_E = 1.1 \text{ cm}$ . The lenses are separated by a distance of 10 cm. If an object is 1.0 cm in front of the objective lens, where will the final image be located (to the nearest cm) with respect to the eyepiece?
- 30 cm
  - 15 cm
  - 23 cm
  - 11 cm

33. A thin lens with focal length  $f$  is to be used as a magnifying glass. Which of the following statements regarding this situation is true?
- A converging lens must be used, and the object be placed at a distance greater than  $2f$  from the lens.
  - A diverging lens must be used, and the object be placed between  $f$  and  $2f$  from the lens.
  - A converging lens must be used, and the object be placed at a distance less than  $f$  from the lens.
  - A diverging lens must be used, and the object be placed at any point other than the focal point.

34. A lens with focal length  $f=35$  cm is used to view a clock 85 cm from the lens. How far from the lens does the clock appear?(select the closest value)
- 120 cm
  - 25 cm
  - 60 cm
  - 50 cm

35. A 100 Watt light bulb is connected to a 120 volt source. What is the resistance of the filament in the bulb (in Ohms)?
- 83.3
  - 144
  - 12000
  - 0.833

36. Find the equivalent capacitance across terminals A and B. That is, find the reading on a capacitance meter placed across terminals A and B of the circuit shown in the figure below.

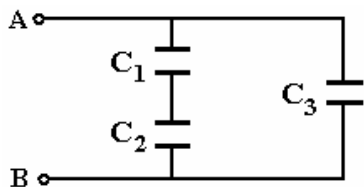

$C_1 = 3.0 \mu\text{F}$ ,  $C_2 = 3.0 \mu\text{F}$ ,  $C_3 = 10.0 \mu\text{F}$

- 16.00  $\mu\text{F}$
- 11.50  $\mu\text{F}$
- 3.75  $\mu\text{F}$
- 1.30  $\mu\text{F}$

37. An oscillator at a frequency of 1.25 Hz will, to two significant figures, make 100 vibrations in a time of
- 125 s
  - 12.5 s
  - 8 s
  - 80 s

38. A mass  $m = 2.0$  kg is attached to a spring having force constant  $k = 300$  N/m as shown:

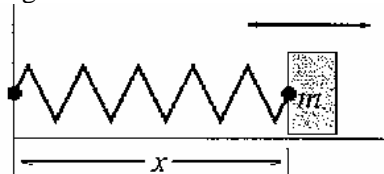

The mass is displaced from its equilibrium position and released. Its frequency of simple harmonic oscillations, to three significant figures is:

- 12.3 Hz
  - 0.533 Hz
  - 0.01 Hz
  - 1.95 Hz
39. Two waves with the same frequency and wavelength but different amplitudes are added. If  $A_1 = 2A_2$  and the waves are  $180^\circ$  out of phase, then the amplitude of the resulting wave will be:
- zero
  - same as  $A_1$
  - same as  $A_2$
  - $A_1 + A_2$
40. In general, doubling the amplitude of a wave:
- doubles the frequency
  - Halves the period
  - Quadruples the energy
  - doubles the speed
41. Ocean waves with a wavelength of 120 m approach the shore at the rate of 8 per minute. What is their speed (to two significant figures)?
- 8 m/s
  - 16 m/s
  - 24 m/s
  - 30 m/s

42. A diffraction pattern is produced by shining light of wavelength  $\lambda$  on a single narrow slit in air. If the same experiment is performed with the apparatus submerged in clear water, then which of the following is true about the spacing between the fringes and the width of the central maximum? Compared to the results in air,

- The spacing increases and the width becomes narrower
- The spacing decreases and the width remains the same
- The spacing increases and the width becomes wider
- The spacing decreases and the width becomes narrower

43. A point source of sound on top of a police car emits a signal at 1000 Hz. If the car is traveling in a straight line at 20.0 m/s, what is the perceived wavelength (to three significant figures) as measured by someone standing on the road directly in front of the car? Take the speed of sound to be 335 m/s.

- 0.305 m
- 0.203 m
- 0.315 m
- 0.335 m

44. What is the gauge pressure at a depth of 6 cm in a glass filled with 4cm of mercury and 4cm of water? Water has a density of  $1000 \text{ kg/m}^3$  and the density of mercury is 13.6 times as great.

- 3.1 kPa
- 5.3 kPa
- 5.7 kPa
- 6.8 kPa

45. A wind with speed 45 m/s blows across a roof 20 m long and 12 m wide. What is the net force on this roof due to the pressure difference inside and outside the roof? (The density of air is  $1.3 \text{ kg/m}^3$ )

- $2.4 \times 10^7 \text{ N}$
- $6.3 \times 10^5 \text{ N}$
- $3.2 \times 10^5 \text{ N}$
- $7.0 \times 10^3 \text{ N}$

46. Which of the following four  $\beta^\pm$  decay processes is possible (where  $\beta^\pm$  stands for  $\beta^+$  or  $\beta^-$ , including the appropriate neutrino or antineutrino)?

Masses of neutral isotopes in  $u$

$^{212}_{84}\text{Po}$	211.99	$^{37}_{18}\text{Ar}$	36.967
$^{208}_{82}\text{Pb}$	207.98	$^{37}_{17}\text{Cl}$	36.966
$^{51}_{22}\text{Ti}$	50.9466	$^{53}_{27}\text{Co}$	52.954
$^{51}_{23}\text{V}$	50.9440	$^{54}_{26}\text{Fe}$	53.940
$\beta^\pm$	0.00055		

- $^{212}_{84}\text{Po} \rightarrow ^{208}_{82}\text{Pb} + \beta^\pm$
- $^{37}_{18}\text{Ar} \rightarrow ^{37}_{17}\text{Cl} + \beta^\pm$
- $^{51}_{22}\text{Ti} \rightarrow ^{51}_{23}\text{V} + \beta^\pm$
- $^{53}_{27}\text{Co} \rightarrow ^{54}_{26}\text{Fe} + \beta^\pm$

47. A point  $P$  is located at a distance  $d$  to the right of a positive point charge  $+q_1$ . When a second point charge  $q_2$  is placed a distance  $d$  to the left of the first charge, the magnitude of the electric field at  $P$  doubles. Which of the following are the two possible values for  $q_2$ ?

- $+q_1$  or  $-2q_1$
- $+2q_1$  or  $-3q_1$
- $+2q_1$  or  $-6q_1$
- $+4q_1$  or  $-12q_1$

48. A  $10^{-4}$  charge is moving at  $10^5 \text{ ms}^{-1}$  parallel to a 4 T magnetic field. The magnitude of the force on the charge is:

- 2 N
- 20 N
- 40 N
- None of the above

49. A particle with a mass of  $6.64 \times 10^{-27}$  kg and a charge of  $+3.20 \times 10^{-19}$  C is accelerated from rest through a potential difference of  $2.45 \times 10^6$  V. The particle then enters a uniform 1.60 T magnetic field. If the particle's velocity is perpendicular to the magnetic field at all times, what is the magnitude of the force exerted on the particle?
- 0 N
  - $1.14 \times 10^{-10}$  N
  - $6.55 \times 10^{-10}$  N
  - $7.87 \times 10^{-12}$  N

Questions 50-52 refer to the figure below

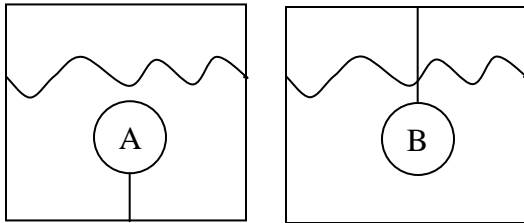

Two balls of the same volume are immersed in water. In system A, the ball is being held under water by a string. In system B, the ball is being prevented from sinking to the bottom by a string attached to the top of the box.

50. Which of the four free body diagrams correspond to system A? (T = tension in string, W = weight of ball, F = buoyant force)

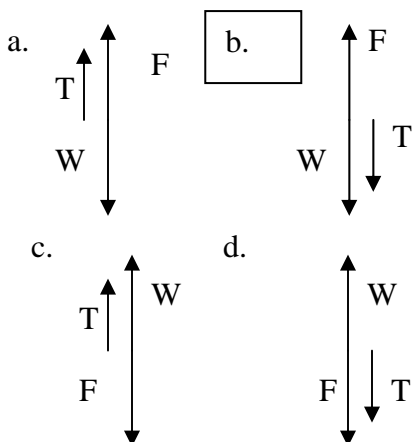

51. You are told that ball A and ball B are suspended in the same liquid, and that they are the same mass. What is the tension in the string?
- $T > 0$
  - $T = 0$
  - $T < 0$
  - It is impossible to tell from the given information
52. If we exchange the water in the figure for another fluid of density  $\rho_{\text{new}}$ , what is the condition on  $\rho_{\text{new}}$  if we want to observe the same behaviour as is exhibited in figure 1, what must be the density of the new liquid?
- $\rho_a > \rho_{\text{new}} > \rho_b$
  - $\rho_a < \rho_{\text{new}} < \rho_b$
  - $\rho_a = \rho_{\text{new}} = \rho_b$
  - $\rho_{\text{new}} = \rho_{\text{water}}$
53. Which of the following is true for an ideal stationary fluid?
- The density increases linearly with depth
  - Only the fluid at the surface is in mechanical equilibrium
  - The fluid below the surface has a propensity toward the mechanical equilibrium
  - The pressure increases linearly with depth
54. A woman floats comfortably in a sitting position in a body of water. Her entire torso (above the belly button) is above the surface of the water. What does this situation tell you about the water?
- It's not possible
  - The water has a dissolved additive (such as salt) which makes it much more dense than fresh water
  - The temperature of the water is significantly higher than normal
  - The woman is wearing a hat made of buoyant material

55. A fish prepares a home for its young by taking gulps of air and blowing saliva coated bubbles which collect at the waters surface. The fertilized eggs are then deposited individually into the bubbles. The bubbles sink until the entire air pocket is immersed in water, then the entire nest remains floating just below the surface of the water. What can we say about the eggs of the fish.
- They have a large mass
  - They are large in volume
  - The have a density greater than water
  - They have a density equal to water

Questions 56-57 refer to the figure below

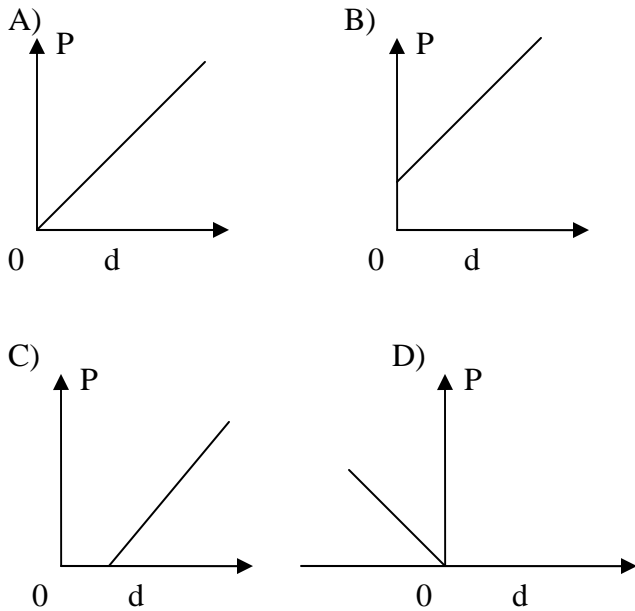

Plots of pressure vs. depth

56. Which of the plots describes pressure (p) with depth below the surface (d)?
- A
  - B
  - C
  - D
57. Which of the plots describes change in pressure change with depth below surface (d)?
- A
  - B
  - C
  - D

58. Two pistons of a hydraulic lift have radii of 2.67 cm and 20.0 cm. The downward force on the 2.67 cm piston that is required to lift a mass of 2000 kg supported by the 20 cm piston is:

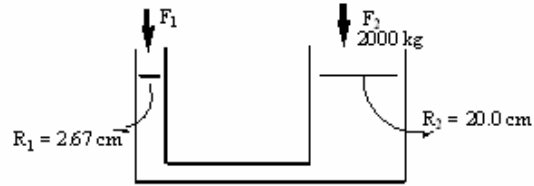

- 270 N
- 350 N
- 36 N
- 1500 N

Questions 59-61 refer to the figure below

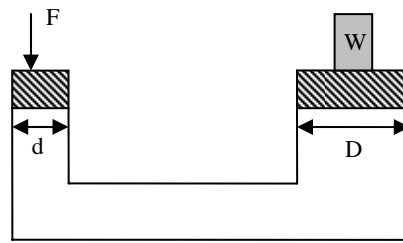

A hydraulic lift

59. A hydraulic lift is shown. if the diameter of the smaller piston (d) is 4.0 cm. The diameter of the larger piston (D) is 40 cm. What weight can the larger piston support when a force of 250 N is applied to the smaller piston?
- 2.5 N
  - 25 N
  - 250 N
  - 25000N
60. A hydraulic lift is shown in figure 4. if the diameter of the smaller piston (d) is 4.0 cm. The diameter of the larger piston (D) is 40 cm. What force must be applied to the small piston in order to lift a 255 kg box?
- 2.5 N
  - 25 N
  - 250 N
  - 2500 N

61. What is the ratio of the diameter of the larger piston to the smaller piston if a 5 N force allows us to support a 125N load
- 1:1
  - 2:1
  - 5:1
  - 10:1
62. The magnitude of the buoyant force on a body is proportional to
- The density of the body
  - The mass of the body
  - The volume of the fluid
  - The density of the medium surrounding the body
63. If I double the density of a fluid the buoyant force on a piece of wood will:
- Increase 4 fold
  - Double
  - Remain unchanged
  - Become  $\frac{1}{2}$  of what it was before

Questions 64-65 refer to the figure below

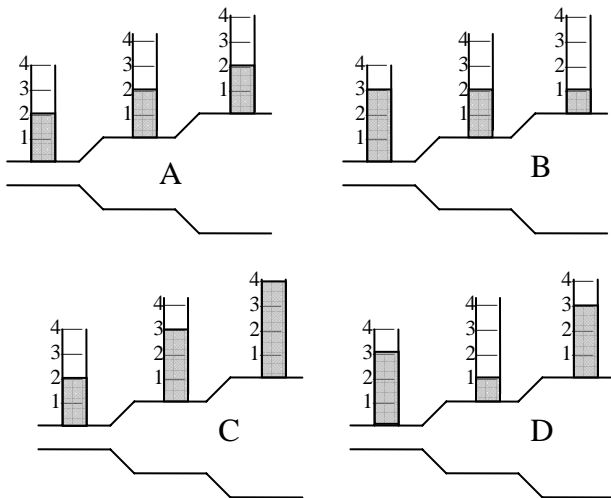

A cylindrical pipe of changing diameter with an ideal dynamic fluid. The vertical tubes are connected to the main tube.

64. Which of the four choices in the figure shows the proper fluid heights if the fluid is flowing from right to left?
- A
  - B
  - C
  - D

65. Which of the four choices in the figure shows the proper fluid heights if the fluid is flowing from left to right?
- A
  - B
  - C
  - D
66. Downtown London has become a more popular residential area, and as a result, the water pressure on the 5<sup>th</sup> floor of a 10 story older apartment building is lower than is comfortable to take a shower. The following strategies are being considered by a student to fix this problem.
- Move to the 1<sup>st</sup> floor
  - Move to the 10<sup>th</sup> floor
  - Expand the width of the shower head
  - Narrow the width of the shower head
- Which of the strategies will work?
- I and III
  - I and IV
  - II and III
  - II and IV

67. A blood vessel of radius  $r$  splits into two smaller vessels, each with a radius of  $r/4$ . If the average speed of the blood in the large vessel is  $v_1$ , what is the average speed of the blood in each of the smaller vessels  $v_s$ .
- $v_s = 8 \times v_1$
  - $v_s = 4 \times v_1$
  - $v_s = v_1$
  - $v_s = v_1/4$

68. An artery is partially stenosed (blocked) by an atherosclerotic plaque. Which of the following statements best describes the system of blood flowing past the constriction?
- Blood will rush faster through the constriction due to the equation of continuity, causing additional damage to the vessel wall
  - Bernoulli's law and the equation of continuity predict a variation of the blood pressure in the constricted zone. The thickened vessel wall prevents any additional damage due to the increase in pressure in the region of the lesion.
  - The blood pressure in the constricted region is lower than the adjacent vessel, causing the blood vessel to temporarily collapse at the constriction.
  - The blood pressure in the constricted region is higher than in the adjacent vessel, causing ballooning of the vessel in the constriction.
69. The volume flow rate in a blood vessel of fixed cross-sectional area is halved. By how much must the blood flow speed change? Treat blood as an incompressible fluid.
- The speed remains unchanged
  - The speed doubles
  - The speed increases four fold
  - The speed is cut in half
70. When a beam of light enters a glass block, it ordinarily undergoes a change in:
- Amplitude only
  - Effective speed only
  - Wavelength only
  - Speed and wavelength

Questions 71-75 refer to the figure below

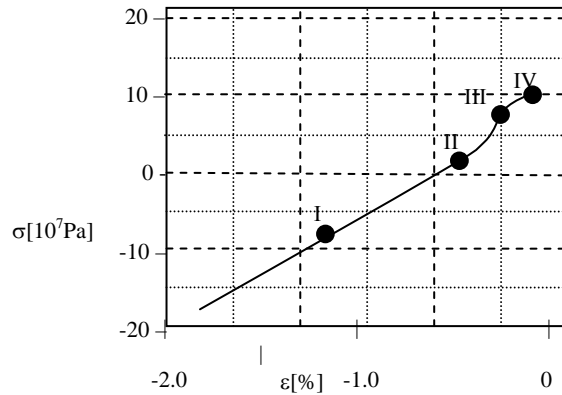

The stress-strain relation of compact bone. Positive values of strain correspond to tension, negative values corresponds to a compression of the bone. In an adult male the femur has a cross-sectional area of  $6.2 \text{ cm}^2$ .

71. Find the maximum tensile force that can be withstood by the bone.
- $1.05 \times 10^5 \text{ N}$
  - $1.05 \times 10^5 \text{ Pa}$
  - $7.4 \times 10^4 \text{ N}$
  - $7.4 \times 10^4 \text{ Pa}$
72. Find the maximum compressive force that can be withstood by the bone.
- $1.05 \times 10^5 \text{ N}$
  - $1.05 \times 10^5 \text{ Pa}$
  - $7.4 \times 10^4 \text{ N}$
  - $7.4 \times 10^4 \text{ Pa}$
73. Examine figure 1: find the maximum compressive stress that can be withstood by the bone.
- $1.05 \times 10^5 \text{ N}$
  - $17 \times 10^7 \text{ Pa}$
  - $7.4 \times 10^4 \text{ N}$
  - $11 \times 10^7 \text{ Pa}$
74. Examine figure 1: at which of the 4 points highlighted along the curve does Hooke's law not apply?
- only i)
  - only iii)
  - both i) and ii)
  - both iii) and iv)

75. Examine figure 1: you conduct a 2 point experiment to determine the young's modulus of bone. If you test the stress strain relationship on just 2 of the four points highlighted in figure one, which pair of points will give you the lowest young's modulus?
- i) and ii)
  - ii) and iii)
  - iii) and iv)
  - i) and iv)

76. Fire engine approaches a wall at 5.00 m/s while its siren emits a tone whose frequency is 500 Hz. The speed of sound in air is 340 m/s. How many beats per second do the people on the fire engine hear?
- 0.00
  - 15.0
  - 29.0
  - 63.0

77. The water level in a vertical glass tube, of length 1.00 meter, can be adjusted to any position in the tube. A tuning fork vibrating at 660 Hz is held just over the open end of the tube. At what positions of the water level will there be a loud resonance for air at 30°C, given that the speed of sound in air at 30°C is 349 m/s?
- 5 cm
  - 7.5 cm
  - 10 cm
  - 12.5 cm

78. A stationary 4 kg shell explodes into three peaces. Two of the fragments have a mass of 1 kg each and move along the paths shown with speed 10 m/s. The third fragment moves upwards as shown. What is the speed of the third fragment immediately after explosion?

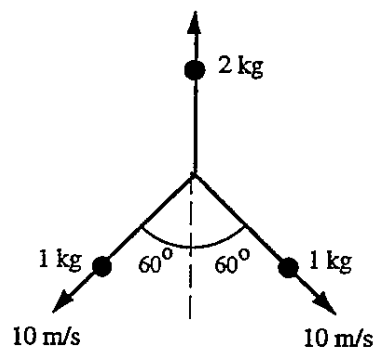

- 0 m/s
  - 5 m/s
  - 10 m/s
  - 20 m/s
79. A 1000 kg motorboat traveling at 5 m/s strikes a 5000 kg ship at rest. Both vessels dock together after collision. What will be the speed of both vessels just after the collision?
77. 0.63 m/s
  78. 0.73 m/s
  79. 0.83 m/s
  80. 0.93 m/s
80. A wire has a resistance of 35.0  $\Omega$ . It is melted down, and from the same volume of metal, a wire is made that is four times longer than the original wire. What is the resistance of the new wire?
- 1000  $\Omega$
  - 560  $\Omega$
  - 780  $\Omega$
  - 920  $\Omega$
81. A diverging lens with a focal length of 25 cm has a magnification of 0.50. How far apart are the object and the image?
- 12.5 cm
  - 25 cm
  - 10 cm
  - 15 cm

82. Three objects  $m_1$ ,  $m_2$ , and  $m_3$  are suspended from three massless and frictionless pulleys as shown in the diagram.  $m_1$  is 6 kg,  $m_2$  is 2 kg, and  $m_3$  is 3 kg. Find the tension of the string when the system is set in motion (i.e. all masses are moving). (This question is too hard to be on the MCAT, but it is good practice)

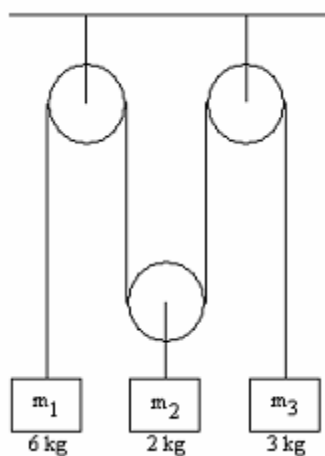

- a. 11.3 N  
 b. 12.1 N  
 c. 13.5 N  
 d. 15.7 N
83. A rod of 2.0 m length and square cross-section (2.0 mm x 2.0 mm) is made of a material with a resistivity of  $6.0 \times 10 \Omega\text{m}$ . If a potential difference of 0.5 V is established across the ends of the rod, at what rate in W is heat generated in the rod?
- a. 3.0  
 b. 5.3  
 c. 8.3  
 d. 1.3

84. The near point of a person is 50cm. The image forms behind the retinal for images closer than 50 cm. To correct this problem, what refractive power must a corrective lens have to enable the eye to see an object at 10cm away clearly?

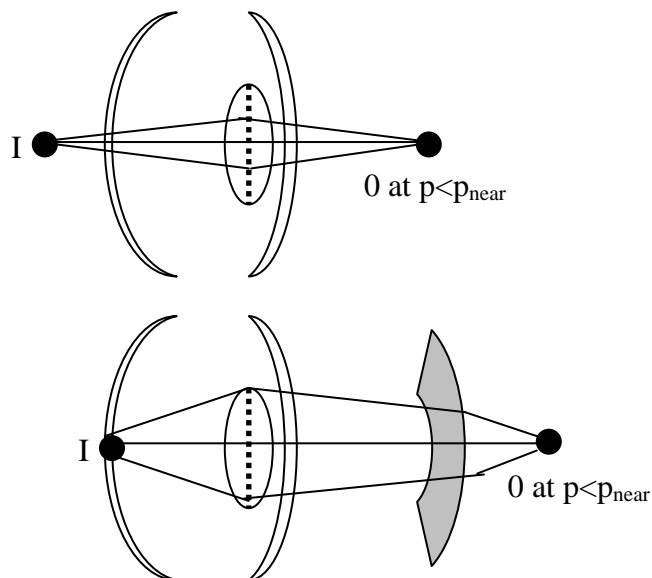

- a. -8.0 dpt  
 b. -2.0 dpt  
 c. 2.0 dpt  
 d. 8.0 dpt
85. The atomic mass of  ${}^9\text{Be}$  is 9.012186 u. That of  ${}^4\text{He}$  is 4.002604u, and of  ${}^{13}\text{C}$  13.003354u. Calculate the energy (in MeV) released by the reaction:  ${}^9\text{Be} + {}^4\text{He} \rightarrow {}^{13}\text{C}$
- a. 10.7 MeV  
 b. 12.3 MeV  
 c. 8.6 MeV  
 d. 15.7 MeV
86. If an object which is attached to a horizontal spring is released from rest and distance +A from equilibrium position of the spring, then
- a. The formula  $E = 1/2 kx^2 + mgx$  describes the total energy of the object  
 b. The formula  $E = 1/2 kA$  describes the maximum potential energy of the object  
 c. The formula  $E = 1/2 kA^2$  describes the total energy of the object  
 d. The formula  $F = -kx^2$  describes the elastic force (restoring force) acting on the object

87. An object is attached to a horizontal spring. It is intentionally displaced by a given distance from equilibrium. If I release the spring, and allow the displacement to  $\frac{1}{2}$  without interference, the total energy of the system changes from  $E_1$  to  $E_2$  with:
- $E_2 = E_1$
  - $E_2 = \frac{1}{2} E_1$
  - $E_2 = 2 E_1$
  - $E_2 = \frac{1}{4} E_1$
88. An object with mass 6 kg is connect to a spring with a spring constant of 42.5 N/m. The object oscillates on a frictionless horizontal surface. If the spring is compressed from 0 to -12 cm and released from rest determine the maximum speed of the object.
- 0.350 m/s
  - 0.320 m/s
  - 0.290 m/s
  - 0.380 m/s
89. Two of the resonant frequencies of a closed pipe are 204 Hz and 476 Hz. If the speed of sound in air is 340 m/s, what is the shortest length of pipe consistent with this data?
- 1.5 m
  - 2.0 m
  - 2.25 m
  - 1.25 m
90. A 2.0 kg block of wood is floating in water. It is found that a downward thrust of 10.0 N submerges the block an additional 10 cm, at which point it is let loose to oscillate up and down. Assuming the motion is simple harmonic and undamped, What is the frequency of the motion?
- 2.3 Hz
  - 1.5 Hz
  - 1.1 Hz
  - 3.1 Hz
91. When two students talk to each other, the sound produced is an example of a(n)
- Transverse wave
  - Longitudinal wave
  - Electromagnetic wave
  - Standing wave
92. The velocity of an ultrasound wave is 1480 m/s in water and 1540 m/s in soft tissue. A beam of ultrasound in water arrives at the interface between water and soft tissue at an angle of incidence  $\theta_i = 35.0^\circ$ . What is the angle of refraction in the soft tissue?
- $42.6^\circ$
  - $53.6^\circ$
  - $36.6^\circ$
  - $22.6^\circ$
93. An object is placed 3mm in front of a positive (converging) lens of focal length 2.7 mm. What is the magnification of the image?
- 3
  - 3
  - 9
  - 9
94. A small sphere with a charge of  $-2.0 \mu\text{C}$  and a mass of 50g hangs from a thin wire of negligible mass. A second sphere of charge  $-3.0 \mu\text{C}$  is brought close to the hanging sphere causing the wire to form an angle of  $20.0^\circ$  with the vertical. What will be the separation of the charges when the spheres come to rest in m?
- 1.12
  - 0.59
  - 0.30
  - 0.55
95. X-rays of wavelength 0.1 nm are required for a particular medical procedure. Which of the following values' is closest to the minimum potential difference, in kV, that must be applied to the X-ray tube?
- 10
  - 12
  - 19
  - 0.12

96. Which of the following values, in MeV, is closest to the maximum energy of the positron released in the decay of  $^{13}_7\text{N}$  to  $^{13}_6\text{C}$ ?

Nucleus	ATOMIC Mass (u)
$^{13}_7\text{N}$	13.005738
$^{13}_6\text{C}$	13.003355

- a. 1.197  
 b. 0.686  
 c. 0.511  
 d. 1.708
97. The sound intensity level at Angela's ear is 70.0 dB. Her ear is 5.00 meters from a point source of sound of frequency 500 Hz. If Angela moves her ear to a distance of 8.00 m from the source, what would be the new sound intensity level at Angela's ear?
- a. 66 dB  
 b. 60 dB  
 c. 56 dB  
 d. 50 dB
98. Ignoring air resistance, if you drop an object, it experiences a force downward of  $m \times 9.81\text{N}$ , and accelerates downwards at  $9.81\text{ m/s}^2$ . If instead you throw it down, what will be the acceleration of the object?
- a.  $9.81\text{ m/s}^2$  upwards  
 b.  $9.81\text{ m/s}^2$  downwards  
 c. More than  $9.81\text{ m/s}^2$  downwards  
 d. Less than  $9.81\text{ m/s}^2$  downwards

99. A mass  $m$  is suspended by a (massless) string forming a simple pendulum of 1.0 m length. The pendulum is initially at an angle of 30 degrees with the vertical when the mass is released. What is the maximum speed of the mass? (Take  $g = 10\text{ m/s}^2$ )
- a. 1.6 m/s  
 b. 2.7 m/s  
 c. 3.5 m/s  
 d. 5.3 m/s

100. Four long straight wires carry equal current into the page as shown.



The direction of magnetic force exerted on the wire on the left is:

- a. right  
 b. left  
 c. up (towards the top of the page)  
 d. down (towards the bottom of the page)
101. Rank the values of the total power dissipated by the circuit in descending order (largest first).

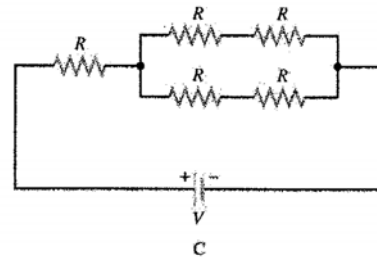
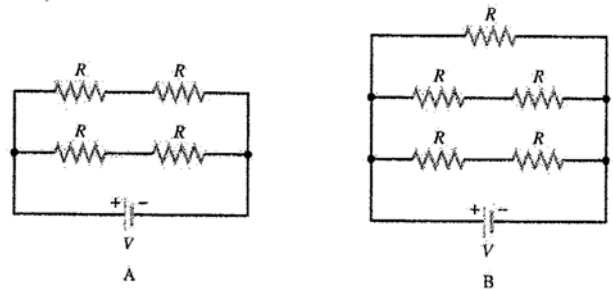

- a. A, B, C  
 b. B, A, C  
 c. C, A, B  
 d. A, C, B
102. A battery is manufactured to have an emf of 24.0V, but the terminal voltage is only 22.0V when the battery is connected across a  $7.5\ \Omega$  resistor. What is the internal resistance of the battery?
- a.  $3.2\ \Omega$   
 b.  $0.27\ \Omega$   
 c.  $1.2\ \Omega$   
 d.  $0.68\ \Omega$